

All dimensions are approximate; for exact dimensions contact your dealer.

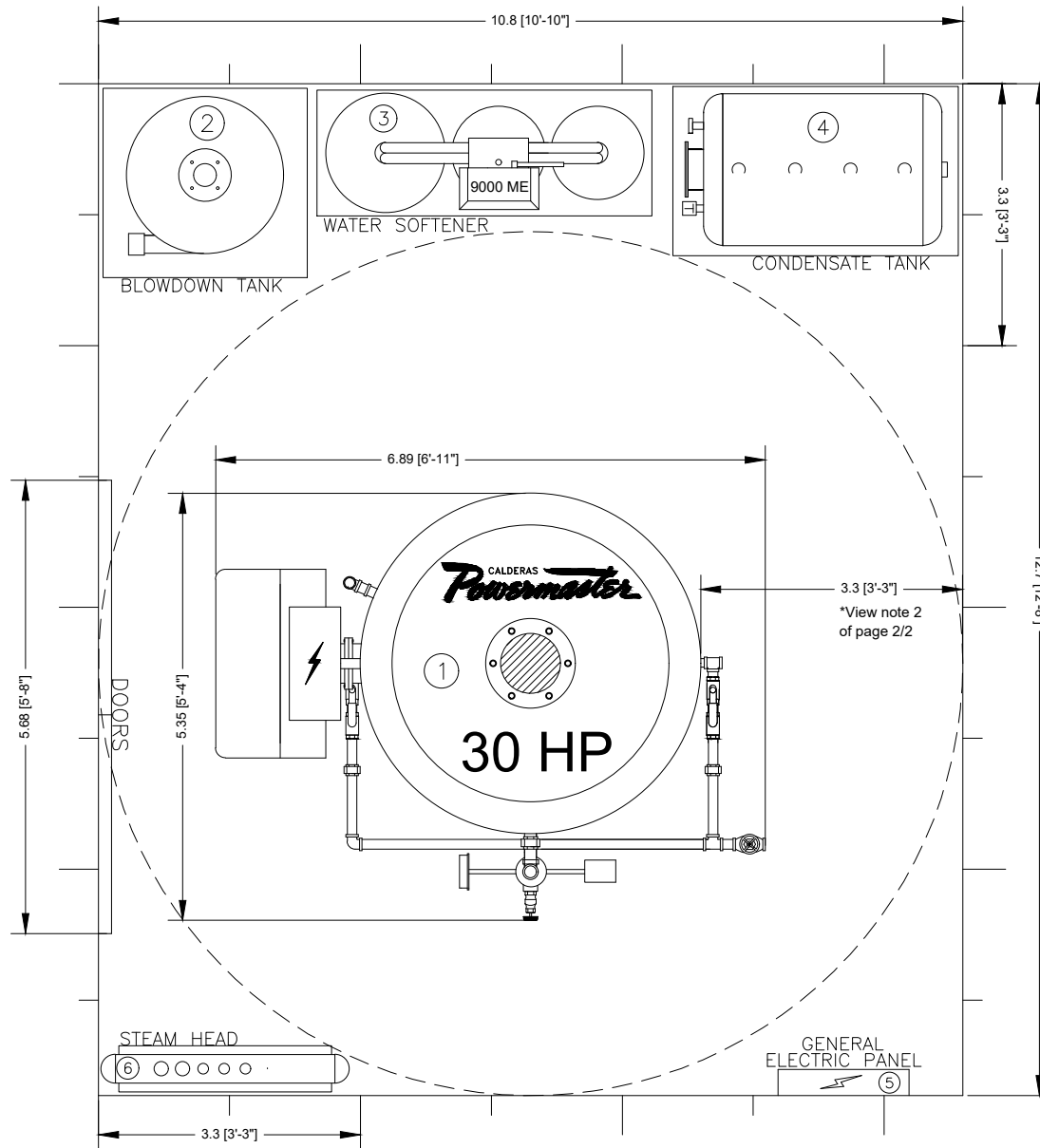

EQUIPMENTS FOR STEAM GENERATION

- ① Steam Powermaster Boiler VT3 30 HP
- ② Blowdown Separator Tank TPG-C40
- ③ Water softener PW2x3F 9000ME/1
- ④ Condensate Tank TCC-N30
- ⑤ General electric panel *
- ⑥ Steam head *

Note: The LAYOUT shown here is typical. The geometry and minimum space required depends on the desired accommodation and purchased equipment. If you require a detailed LAYOUT of your budget, contact your dealer.

* Check dimensions with your dealer

| | | | |
|---|------------------|--|---------------------|
|  | | TERMODINAMICA ENICA S.A. DE C.V. Av. Dr. Jiménez Cantú Lote 2.5 s/n, Plaza Antigua Edif 3 Ofi. 3-16 Atizapán de Zaragoza, Edo. de México, CP. 52937 Tel. 53-93-57-11 / 84-49 | |
| | | BOILER: Powermaster VT3 30 HP | |
| DIMENSIONING: | ft [ft-in] | PROJECT: | LAYOUT |
| PAGE: | 1 / 2 | FUEL: | NATURAL GAS, L.P.G. |
| DRAWN BY: | ING. J. CHAPARRO | REVIEWED BY: | SALES DEPT. |
| | | AUTHORIZED BY: | ING. J. NOTHOLT |

Termodinámica Enica S.A. de C.V. reserves the right to make changes to this drawing without notice.

GENERAL NOTES

1. The arrangement suggested here, can be modified to suit different geometries.
2. Powermaster recommends a distance between the pressure container and another equipment or wall of minimum 3.3 ft.
3. The save valves must be calibrated to the boiler design pressure.
4. Powermaster recommends to use black carbon steel pipes schedule 40 or 80 except the local norm applicable.
5. The water temperature in the receptor condensate tank have to be minimum 176°F.
6. The water softener equipment must to make up with filtered water. Check with the manufacturer the adequate pressure.
7. When steam is feed to condensate tank it must be feed to low pressure (Maximum 28 PSI) for reduce the noise.
8. It must to install a Barometric draft regulator when the height smokestack is greater than 26.2 ft. Powermaster recommend to install straight smokestacks and independently.
9. When it can't install independent smokestack, view detail "B".
10. It must to install a ground to the electric panel.
11. The download of safe valves must be with black carbon steel pipes schedule 40 and vent outdoor.
12. Install independent switch thermomagnetic for each boiler. Check with your dealer the capacity switch.
13. The boiler burner has to be feeded with filtered gas to constant pressure, it has to install an appropriate gas pressure regulator for the fluid and the required pressure (check with the manufacturer). The regulator has to be exclusively for the boiler burner and Powermaster recommend have a relief valve calibrated to the maximum permissible pressure (consult with the manufacturer).
14. All the equipments indicated in this LAYOUT must be install inside the ventilated machine room. The equipments must not be outdoor.
15. Powermaster recommend build trenches inside the machine room for a well distribution pipes. Suggested Trench (View detail "A")

All dimensions are approximate; for exact dimensions contact your dealer.

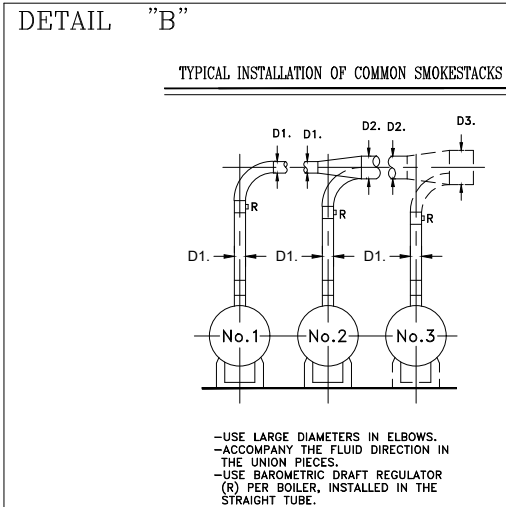
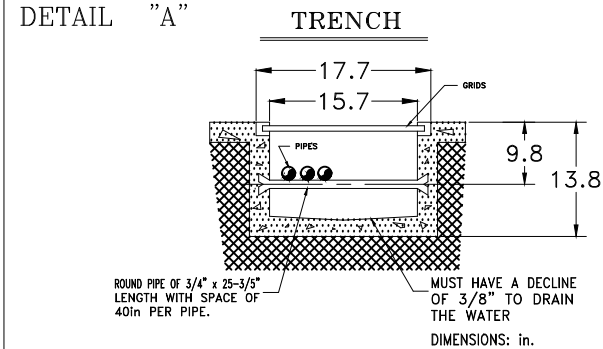

* Check dimensions with your dealer

| | | | |
|---------------------------------------|--------------|---|--|
| CALDERAS Powermaster | | TERMODINAMICA ENICA S.A. DE C.V. Av. Dr. Jiménez Cantú Lote 2.5 s/n, Plaza Antigua Edif 3 Ofic. 3-16 Alzapan de Zaragoza, Edo. de México, CP. 52997 Tel. 53-95-57-11 98-69 | |
| BOILER: Powermaster VT3 30 HP | | | |
| DIMENSIONING: | PROJECT: | # ORDER: | |
| in | LAYOUT | N/A | |
| PAGE: | FUEL: | NATURAL GAS, L.P.G. | |
| 2 / 2 | | | |
| DRAWN BY: | REVIEWED BY: | AUTHORIZED BY: | |
| ING. J. CHAPARRO | SALES DEPT. | ING. J. NOTHOLT | |