

Powermaster Series SWB

Three pass Semi-Wet-Back Steam Boilers



Boiler Data Sheet

MODEL BHP

Maximum allowable working pressure 15 psig

NOMINAL CAPACITIES		10	15	20	25	30	40	50	60
Steam generation from and at 212 °F & 1 atm.	lb/hr	345	518	690	863	1,035	1,380	1,725	2,070
Heating Surface	SQFT	50	75	100	125	150	200	250	300
Boiler Output	MBH	335	502	670	837	1,004	1,339	1,674	2,009

FIRING RATE FOR BURNER SELECTION*		10	15	20	25	30	40	50	60
No. 2 Oil - Diesel (140,000 BTU/gal)	gal/hr	3.0	4.5	6.0	7.5	9.0	12.0	14.9	17.9
Natural Gas (1,000 BTU/ft3)	ft3/hr	418	628	837	1,046	1,255	1,674	2,092	2,511
LP Gas (91,500 BTU/gal)	gal/hr	4.6	6.9	9.1	11.4	13.7	18.3	22.9	27.4

WEIGHTS		10	15	20	25	30	40	50	60
Empty Boiler	lb	3,653	3,653	3,653	4,720	4,720	5,172	6,618	6,618
Flooded Boiler	lb	6,290	6,290	6,290	9,138	9,138	9,568	11,872	11,872

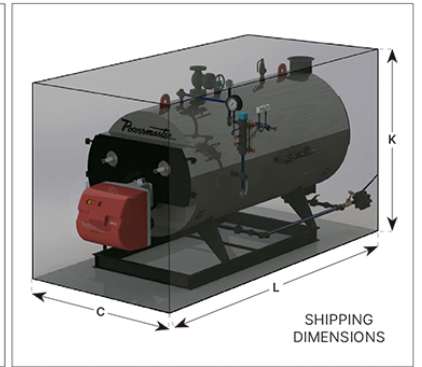
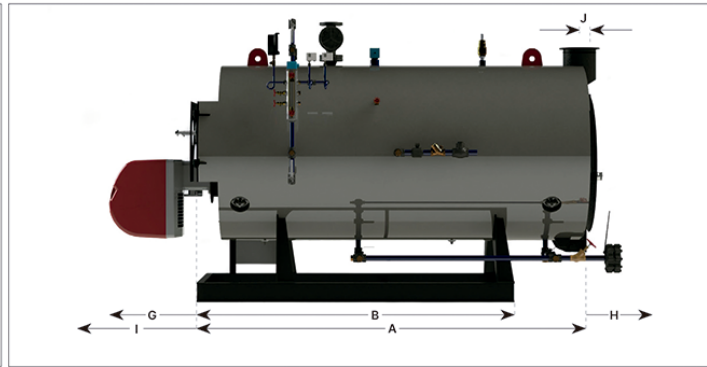
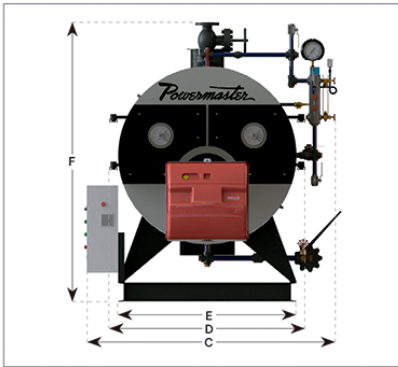

DIMENSIONS		10	15	20	25	30	40	50	60
A Boiler Length	ft	6.92	6.92	6.92	8.43	8.43	8.96	10.20	10.20
B Base Length	ft	5.54	5.54	5.54	6.73	6.73	7.15	8.17	8.17
C Total Width	ft	5.81	5.81	5.81	6.20	6.20	6.20	6.50	6.50
D Limit Width**	ft	4.40	4.40	4.40	4.79	4.79	4.79	5.09	5.09
E Base Width	ft	3.97	3.97	3.97	4.40	4.40	4.40	4.69	4.69
F Total Height (to steam outlet)	ft	5.48	5.48	5.48	5.94	5.94	5.97	6.40	6.40
G Front access clearance for maintenance	ft	1.97	1.97	1.97	2.20	2.20	2.20	2.33	2.33
H Back access clearance for maintenance	ft	2.92	2.92	2.92	3.08	3.08	3.15	3.54	3.54
I Front flux tubes exchange clearance	ft	5.64	5.64	5.64	6.73	6.73	7.28	8.27	8.27
J Smoke stack center to back of boiler	ft	-0.10	-0.10	-0.10	-0.07	-0.07	-0.03	-0.03	-0.03
K Shipping height	ft	6.23	6.23	6.23	6.30	6.30	6.30	6.59	6.59
L Shipping length (includes burner)	ft	9.25	9.25	9.25	11.55	11.55	12.17	13.45	13.45

CONNECTIONS		10	15	20	25	30	40	50	60
Smoke Stack Diameter	in	8	8	8	9	9	10	10	10
Main steam outlet diameter	in	2 1/2	2 1/2	2 1/2	3	3	3	4	4
Boiler feedwater diameter	in	1	1	1	1 1/4	1 1/4	1 1/4	1 1/4	1 1/4
Water Softener feedwater diameter	in	3/4	3/4	3/4	3/4	3/4	3/4	3/4	3/4
Bottom blowdown diameter	in	1	1	1	1	1	1	1 1/4	1 1/4
Level Control blowdown diameter	in	1	1	1	1	1	1	1	1
Surface blowdown diameter	in	1	1	1	1	1	1	1	1

FOUNDATION BASES		10	15	20	25	30	40	50	60
M Total width of base	ft	4.69	4.69	4.69	5.12	5.12	5.12	5.41	5.41
N Distance between bases	ft	2.72	2.72	2.72	3.15	3.15	3.15	3.44	3.44
O Width of each bases	ft	0.98	0.98	0.98	0.98	0.98	0.98	0.98	0.98
P Length of bases	ft	6.20	6.20	6.20	7.38	7.38	7.81	8.83	8.83
Q Height of bases	ft	0.66	0.66	0.66	0.66	0.66	0.66	0.66	0.66

* The actual firing rate depends on fuel quality, burner selection and adjustment, combustion controls, operating pressure, etc. For an estimated calculation of a specific configuration contact your Powermaster salesman.

** Width for freight clearance

Date: ABR 08, 2026

Creator: SZ

Revision: LN

Powermaster Boilers reserves the right to make modifications to this sheet without notice. All dimensions are approximate and indicative only.

Powermaster LLC
24527 Gosling Rd J101, Spring, TX 77389, T. +1 346 382 2407

www.powermasterboiler.com