

Powermaster Series VT3

Two pass Vertical Steam Boilers



Boiler Data Sheet

MODEL BHP

Maximum allowable working pressure 15 psig

NOMINAL CAPACITIES		5	10	15	20	25	30	35	40	50	60
Steam generation from and at 212 °F &	lb/hr	173	345	518	690	863	1,035	1,208	1,380	1,725	2,070
Heating Surface	SQFT	35	35	70	70	105	105	140	140	210	210
Boiler Output	MBH	167	335	502	670	837	1,004	1,172	1,339	1,674	2,009

FIRING RATE FOR BURNER SELECTION*											
Natural Gas (1,000 BTU/ft ³)	ft ³ /hr	209	418	628	837	1,046	1,255	1,465	1,674	2,092	2,511
LP Gas (91,500 BTU/gal)	gal/hr	2.3	4.6	6.9	9.1	11.4	13.7	16.0	18.3	22.9	27.4

WEIGHTS											
Empty Boiler	lb	1,801	1,801	2,513	2,513	3,353	3,353	4,253	4,253	5,959	5,959
Flooded Boiler	lb	2,388	2,388	3,494	3,494	4,806	4,806	6,146	6,146	8,655	8,655

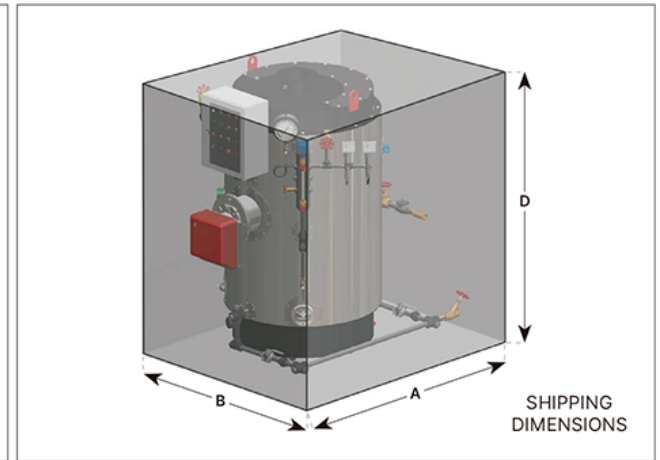
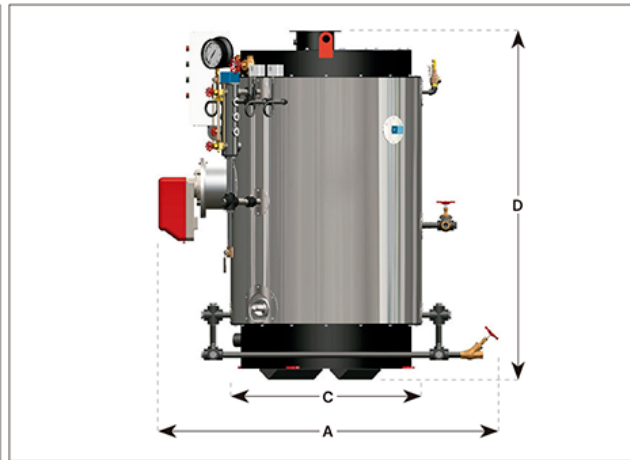
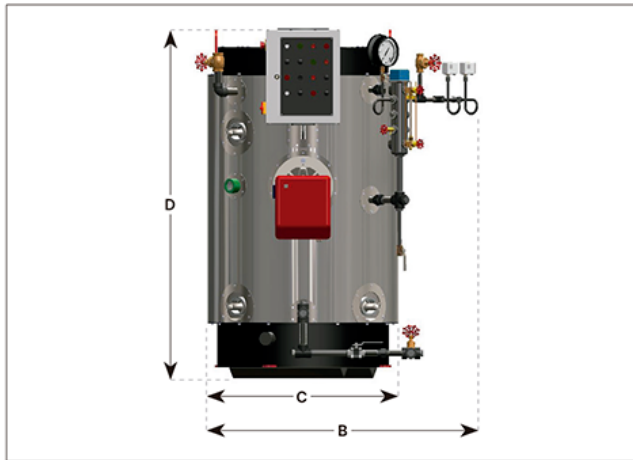

DIMENSIONS			5	10	15	20	25	30	35	40	50	60
A Boiler Length	ft		5.25	5.25	6.23	6.23	6.89	6.89	8.63	8.63	9.55	9.55
B Total Width	ft		3.97	3.97	4.66	4.66	5.35	5.35	5.91	5.91	6.82	6.82
C Limit Width**	ft		2.69	2.69	3.38	3.38	4.07	4.07	4.63	4.63	5.54	5.54
D Total Height	ft		5.71	5.71	6.30	6.30	6.40	6.40	6.59	6.59	6.76	6.76

CONNECTIONS			5	10	15	20	25	30	35	40	50	60
Smoke Stack Diameter	in		6	6	8	8	9	9	10	10	10	10
Main steam outlet diameter	in		1 1/2	1 1/2	2 1/2	2 1/2	3	3	3	3	4	4
Boiler feedwater diameter	in		1	1	1	1	1 1/4	1 1/4	1 1/4	1 1/4	1 1/4	1 1/4
Water Softener feedwater diameter	in		3/4	3/4	3/4	3/4	3/4	3/4	3/4	3/4	3/4	3/4
Bottom blowdown diameter	in		1	1	1	1	1	1	1	1	1 1/4	1 1/4
Level Control blowdown diameter	in		1	1	1	1	1	1	1	1	1	1

* The actual firing rate depends on fuel quality, burner selection and adjustment, combustion controls, operating pressure, etc. For an estimated calculation of a specific configuration contact your Powermaster salesman.

** Width for freight clearance

Date: JUN 15, 2021
 Creator: SZ
 Revision: LN

Powermaster Boilers reserves the right to make modifications to this sheet without notice. All dimensions are approximate and indicative only.

Powermaster LLC
 24527 Gosling Rd J101, Spring, TX 77389, T. +1 346 382 2407

www.powermasterboiler.com