

Boiler Data Sheet

MODEL BHP

Maximum allowable working pressure 150 psig

NOMINAL CAPACITIES		80	100	125	150	200	250	300	350	400	500	600	700	800	900	1000	1100	1200	1300	1400	1500
Steam generation from and at 212 °F & 1 atm.	lb/hr	2,760	3,450	4,313	5,175	6,900	8,625	10,350	12,075	13,800	17,250	20,700	24,150	27,600	31,050	34,500	37,950	41,400	44,850	48,300	51,750
Heating Surface	SQFT	400	500	625	750	1,000	1,250	1,500	1,750	2,000	2,500	3,000	3,500	3,792	4,032	4,160	4,477	4,800	5,122	5,474	5,895
Boiler Output	MBH	2,678	3,348	4,185	5,022	6,695	8,369	10,043	11,717	13,391	16,738	20,086	23,434	26,781	30,129	33,477	36,824	40,172	43,520	46,867	50,215

FIRING RATE FOR BURNER SELECTION*		80	100	125	150	200	250	300	350	400	500	600	700	800	900	1000	1100	1200	1300	1400	1500
No. 2 Oil - Diesel (140,000 BTU/gal)	gal/hr	23.9	29.9	37.4	44.8	59.8	74.7	89.7	104.6	119.6	149.4	179.3	209.2	239.1	269.0	298.9	328.8	358.7	388.6	418.5	448.3
Natural Gas (1,000 BTU/ft ³)	ft ³ /hr	3,348	4,185	5,231	6,277	8,369	10,461	12,554	14,646	16,738	20,923	25,107	29,292	33,476	37,661	41,845	46,030	50,214	54,399	58,583	62,768
LP Gas (91,500 BTU/gal)	gal/hr	36.6	45.7	57.2	68.6	91.5	114.3	137.2	160.1	182.9	228.7	274.4	320.1	365.9	411.6	457.3	503.1	548.8	594.5	640.3	686.0
Heavy Oil (150,000 BTU/gal)	gal/hr	22.3	27.9	34.9	41.8	55.8	69.7	83.7	97.6	111.6	139.5	167.4	195.3	223.2	251.1	279.0	306.9	334.8	362.7	390.6	418.5

WEIGHTS		80	100	125	150	200	250	300	350	400	500	600	700	800	900	1000	1100	1200	1300	1400	1500
Empty Boiler	lb	12,357	13,669	16,564	18,076	22,272	26,035	29,514	33,052	37,393	43,138	55,450	64,509	69,301	71,749	74,837	79,150	82,847	86,732	90,120	93,976
Flooded Boiler	lb	20,818	22,783	27,902	30,474	38,598	46,784	53,096	60,706	68,339	78,628	98,829	112,332	124,815	129,259	133,144	138,843	149,323	157,297	163,131	170,494

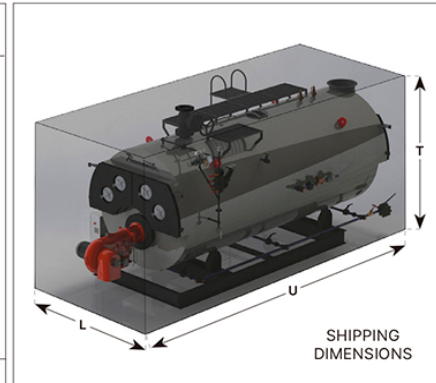
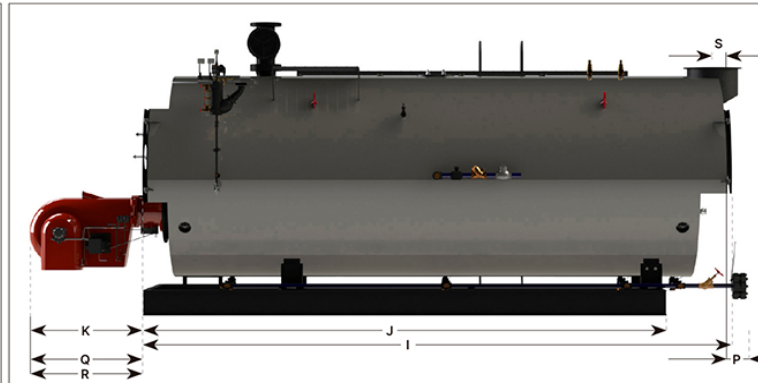
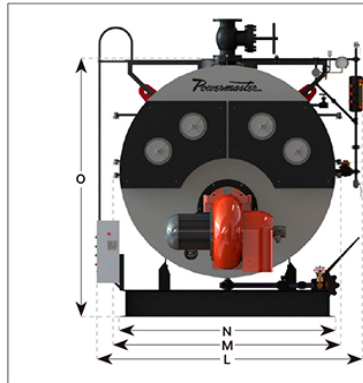

DIMENSIONS		80	100	125	150	200	250	300	350	400	500	600	700	800	900	1000	1100	1200	1300	1400	1500
I Boiler Length	ft	12.50	13.42	14.34	14.50	16.50	17.32	17.75	20.34	20.93	22.44	23.85	26.05	26.12	26.12	26.12	26.21	26.21	26.38	26.54	27.26
J Base Length	ft	9.84	10.73	11.38	11.58	13.12	13.81	14.14	18.11	18.60	20.05	21.52	23.56	23.56	23.56	23.72	23.72	23.79	23.88	24.51	
K Burner Length (estimated) **	ft	2.40	2.40	2.85	2.85	3.64	3.64	3.64	5.41	5.25	5.38	5.38	5.09	5.31	5.31	5.31	6.92	6.92	6.86	6.76	6.69
L Total Width	ft	7.15	7.22	7.55	7.81	8.27	8.83	9.25	9.25	9.65	9.97	10.50	10.79	11.32	11.52	11.58	11.71	12.07	12.34	12.50	12.60
M Limit Width***	ft	5.97	6.04	6.36	6.63	7.09	7.64	8.07	8.07	8.46	8.79	9.32	9.61	10.14	10.33	10.40	10.53	10.89	11.15	11.32	11.42
N Base Width	ft	5.31	5.38	5.71	5.97	6.43	6.99	7.41	7.41	7.81	8.14	8.66	8.96	9.48	9.68	9.74	9.88	10.24	10.50	10.66	10.76
O Total Height (to steam outlet)	ft	6.66	6.75	7.19	7.45	7.91	8.50	8.92	9.51	9.88	10.37	10.66	11.22	11.38	11.38	11.75	11.88	12.27	12.57	12.73	12.80
P Back access clearance for maintenance	ft	2.66	2.69	2.85	2.99	3.22	3.49	3.71	3.71	3.90	4.07	4.33	4.48	4.74	4.84	4.87	4.94	5.12	5.25	5.33	5.38
Q Front access clearance for maintenance	ft	2.66	2.69	2.85	2.99	3.22	3.49	3.71	3.71	3.90	4.07	4.33	4.48	4.74	4.84	4.87	4.94	5.12	5.25	5.33	5.38
R Front flux tubes exchange clearance	ft	10.27	11.18	11.94	12.10	14.01	14.60	14.93	17.52	17.68	19.13	20.54	22.28	22.28	22.28	22.28	22.28	22.28	22.21	22.11	22.57
S Smoke stack center to back of boiler	ft	0.23	0.30	0.16	0.16	0.16	0.16	0.23	0.16	0.16	0.16	0.10	0.10	0.10	0.00	-0.10	-0.10	-0.13	-0.13	-0.10	-0.03
T Shipping height	ft	7.25	7.35	7.74	8.01	8.46	9.02	9.45	9.45	10.01	10.37	10.86	11.15	11.68	11.84	12.17	12.34	12.70	12.93	13.09	13.19
U Estimated shipping length (includes burner)	ft	15.29	16.14	17.75	17.91	20.83	21.75	22.18	26.61	27.10	28.81	30.38	32.38	32.78	32.94	33.10	34.88	34.97	35.14	35.24	35.86

CONNECTIONS		80	100	125	150	200	250	300	350	400	500	600	700	800	900	1000	1100	1200	1300	1400	1500
Smoke Stack Diameter	in	12	12	14	14	16	18	20	20	22	24	26	28	30	32	34	36	37	39	40	41
Main steam outlet diameter	in	3	3	4	4	4	6	6	6	8	8	8	8	8	10	10	10	10	12	12	12
Boiler feedwater diameter	in	1 1/4	1 1/4	1 1/2	1 1/2	1 1/2	2	2	2	2	2	2	2	2.5 ****	2.5 ****	3	3	3	3	3	3
Bottom blowdown diameter	in	1 1/4	1 1/4	1 1/2	1 1/2	1 1/2	1 1/2	1 1/2	1 1/2	2	2	2	2	2	2	2	2	2	2	2	2
Level Control blowdown diameter	in	1	1	1	1	1	1	1	1	1	1	1	1	1	1	1	1	1	1	1	1
Surface blowdown diameter	in	1	1	1	1	1	1	1	1	1	1	1	1	1	1	1	1	1	1	1	1

FOUNDATION BASES		80	100	125	150	200	250	300	350	400	500	600	700	800	900	1000	1100	1200	1300	1400	1500
Total width of base	ft	6.04	6.10	6.43	6.69	7.15	7.71	8.14	8.14	8.53	8.86	9.38	9.68	10.20	10.40	10.47	10.60	10.96	11.22	11.38	11.48
Distance between bases	ft	4.07	4.13	4.46	4.72	5.18	5.74	6.17	6.17	6.56	6.89	7.41	7.71	8.23	8.43	7.71	7.84	8.20	8.46	8.63	8.73
Width of each bases	ft	0.98	0.98	0.98	0.98	0.98	0.98	0.98	0.98	0.98	0.98	0.98	0.98	0.98	0.98	1.38	1.38	1.38	1.38	1.38	1.38
Length of bases	ft	10.50	11.38	12.04	12.24	13.78	14.47	14.80	17.77	18.26	20.70	22.18	24.21	24.21	24.38	24.38	24.38	24.38	24.44	24.54	25.16
Height of bases	ft	0.66	0.66	0.66	0.66	0.66	0.66	0.66	0.66	0.66	0.66	0.66	0.66	0.66	0.66	0.66	0.66	0.66	0.66	0.66	0.66

* The actual firing rate depends on fuel quality, burner selection and adjustment, combustion controls, operating pressure, etc. For an estimated calculation of a specific configuration contact your Powermaster salesman.
 ** Dimensions varies based on burner selection.
 *** Width for freight clearance.
 **** The boiler shell has a 2.5 in coupling. If the boiler is acquired with feed-water piping it will be delivered with a reduction and 2 in valves.

Date: NOV 11, 2022
 Creator: SZ
 Revision: LN

Powermaster Boilers reserves the right to make modifications to this sheet without notice. All dimensions are approximate and indicative only.

Powermaster LLC
 24527 Gosling Rd J101, Spring, TX 77389, T. +1 346 382 2407