

All dimensions are approximate; for exact dimensions contact your representative.

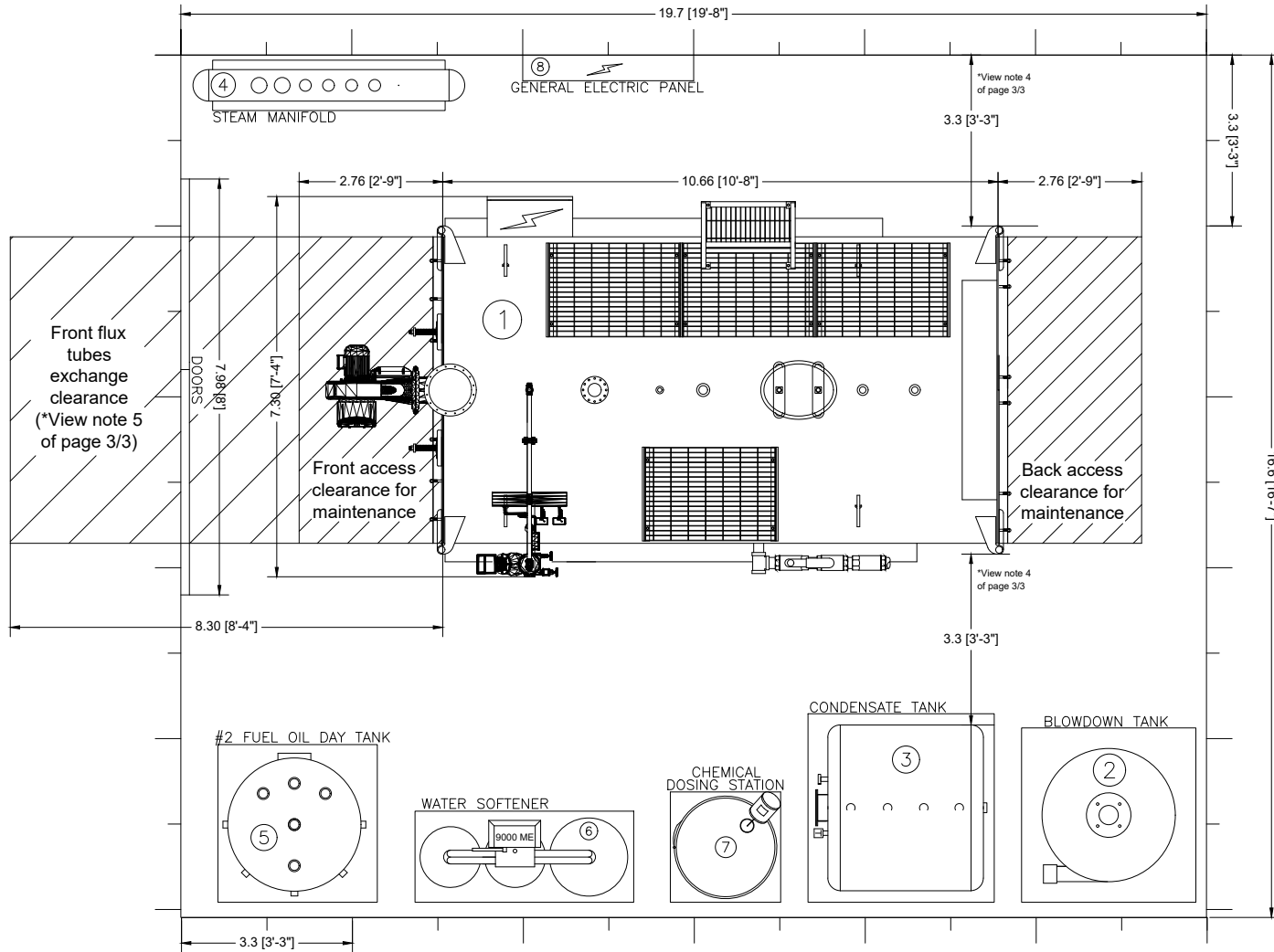

Termodinámica Enica, S.A. de C.V. reserves the right to make changes to this drawing without notice

EQUIPMENTS FOR STEAM GENERATION

- ① Powermaster Steam Boiler WB-A2-4P 80 HP
- ② Blowdown Separator Tank TPG-C100
- ③ Condensate Tank TCC-N80
- ④ Steam manifold
- ⑤ #2 Fuel Oil day tank TT1-450 CB
- ⑥ Water softener PW2x3F 9000 ME/1
- ⑦ Chemical dosing station *
- ⑧ General electric panel *

Note: The LAYOUT shown here is typical. The geometry and minimum required space depends on the desired locations and scope of equipment. If you require a detailed layout of your project, request it from your representative.

* Check dimensions with your representative

Powermaster		TERMODINÁMICA ENICA S.A. DE C.V. Blvd. Dr. Jorge Jiménez Cantú S/N Plaza Antigua Edif. 3 Int. 316 Col. Hacienda de Valle Escondido Atzacapan de Zaragoza, Estado de México C.P. 52937 Tel. 53-93-5711 / 84-49	
		PROJECT: Powermaster WB-A2-4P 80 HP	
DIMENSIONING: ft [ft-in]		PROJECT: LAYOUT	# ORDER: N/A
PAGE: 1 / 3	FUEL: HEAVY OIL, LIGHT OIL, GAS, DUAL	DRAWN BY: ING. J. DOMINGUEZ	
DRAWN BY: ING. J. DOMINGUEZ		REVIEWED BY: SALES DEPT.	AUTHORIZED BY: ING. J. NOTHOLT

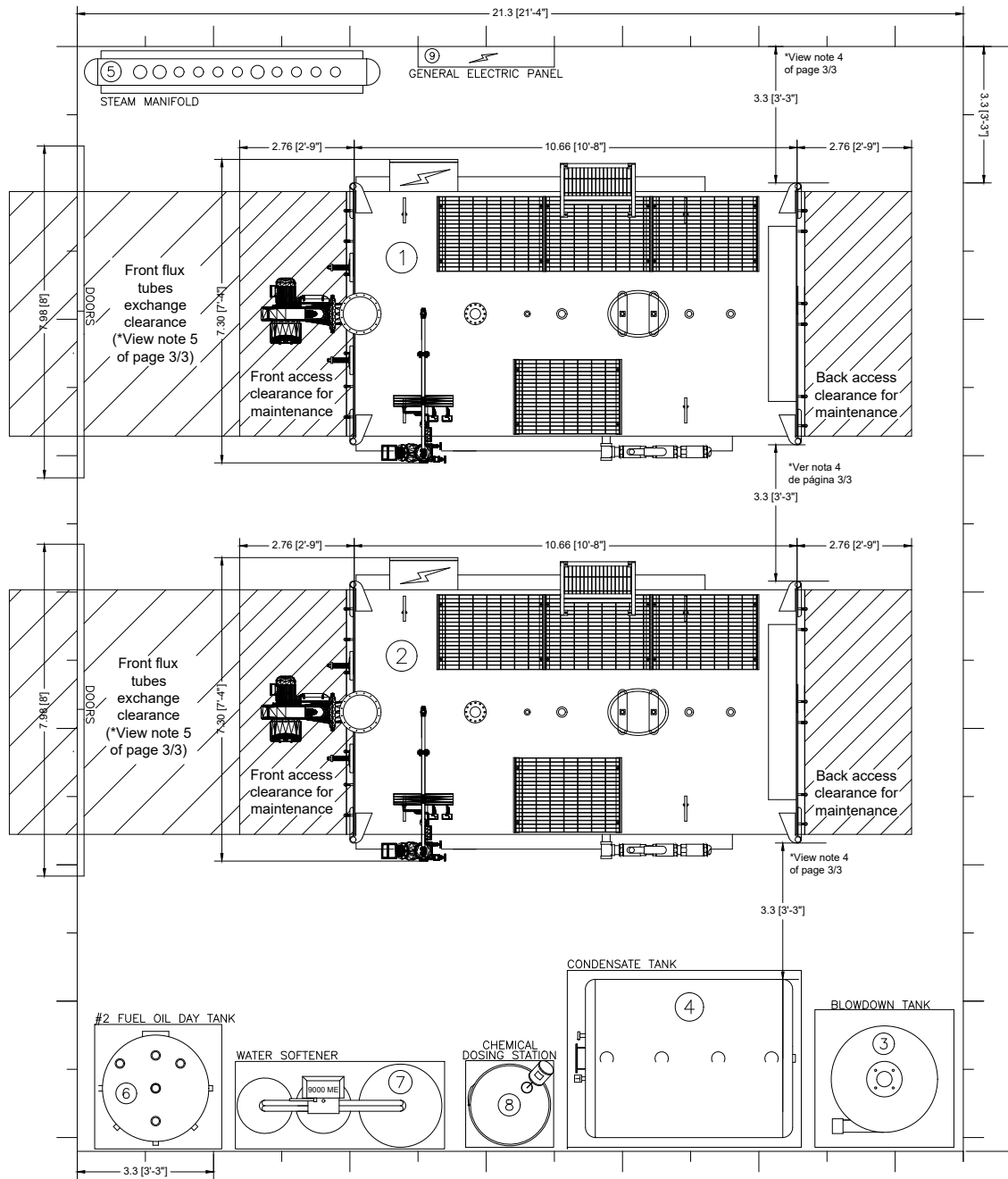

EQUIPMENTS FOR STEAM GENERATION

- ① Powermaster Steam Boiler WB-A2-4P 80 HP
- ② Powermaster Steam Boiler WB-A2-4P 80 HP
- ③ Blowdown Separator Tank TPG-C100
- ④ Condensate Tank TCC-N200
- ⑤ Steam manifold
- ⑥ #2 Fuel Oil day tank TT1-450 CB
- ⑦ Water softener PW2x4F 9000 ME/1
- ⑧ Chemical dosing station *
- ⑨ General electric panel *

Note: The LAYOUT shown here is typical. The geometry and minimum required space depends on the desired locations and scope of equipment. If you require a detailed layout of your project, request it from your representative.

All dimensions are approximate; for exact dimensions contact your representative.

Termodinámica Enica, S.A. de C.V. reserves the right to make changes to this drawing without notice

		* Check dimensions with your representative TERMODINÁMICA ENICA S.A. DE C.V. Blvd. Dr. Jorge Jiménez Cantón S/N Plaza Antigua Edif. 3 Int. 316 Col. Hacienda de Valle Escondido Alcabán de Zaragoza, Estado de México C.P. 52937 Tel. 53-83-67-11 / 84-49			
		Powermaster BOILER: Powermaster WB-A2-4P 80 HP			
DIMENSIONING:	ft [ft-in]	PROJECT:	LAYOUT	# ORDER:	N/A
PAGE:	2 / 3	FUEL:	HEAVY OIL, LIGHT OIL, GAS, DUAL		
DRAWN BY:	ING. J. DOMINGUEZ	REVIEWED BY:	SALES DEPT.	AUTHORIZED BY:	ING. J. NOTHOLT

GENERAL NOTES

1. Powermaster recommends to use foundation bases for the boilers. View detail "A"
2. The Powermaster boilers don't need be anchored to the floor.
3. The arrangement suggested here, can be modified to suit different geometries.
4. Powermaster recommends a distance between the pressure container and another equipment or wall of minimum 3.3 ft.
5. The space for flux tubes exchange clearance is requires only 1 time per year or less.
6. The save valves must be calibrated to the boiler design pressure.
7. Powermaster recommends to use black carbon steel pipes schedule 40 or 80 except the local norm applicable.
8. The water temperature in the receptor condensate tank have to be minimum 176°F.
9. The water softener equipment must to make up with filtered water. Check with the manufacturer the adequate pressure.
10. When steam is feed to condensate tank it must be feed to low pressure (Maximum 28 PSI) for reduce the noise.
11. It must to install a Barometric draft regulator when the height smokestack is greater than 26.2 ft. Powermaster recommend to install straight smokestacks and independently.
12. When it can't install independent smokestack, view detail "C".
13. It must to install a ground to the electric panel.
14. The download of safe valves must be with black carbon steel pipes schedule 40 and vent outdoor.
15. Install independent switch thermomagnetic for each boiler. Check with your dealer the capacity switch.
16. The safe valves numbers depends of size boiler. Please check with your dealer.
17. The boiler burner has to be feeded with filtered gas to constant pressure, it has to install an appropriate gas pressure regulator for the fluid and the required pressure (check with the manufacturer). The regulator has to be exclusively for the boiler burner and Powermaster recommend have a relief valve calibrated to the maximum permissible pressure (consult with the manufacturer).
18. In Diesel boilers must be install a return diesel line. The line have to be independent for each boiler and without accessories like valves, filters, etc.
19. The drain line of diesel tank must be send to hazardous waste container.
20. The vent of diesel day tank must be have with height that exceeding the maximum height of the principal diesel tanks.
21. All the equipments indicated in this LAYOUT must be install inside the ventilated machine room. The equipments must not be outdoor.
22. Powermaster recommend build trenches inside the machine room for a well distribution pipes. Suggested Trench (View detail "B").

All dimensions are approximate; for exact dimensions contact your representative.

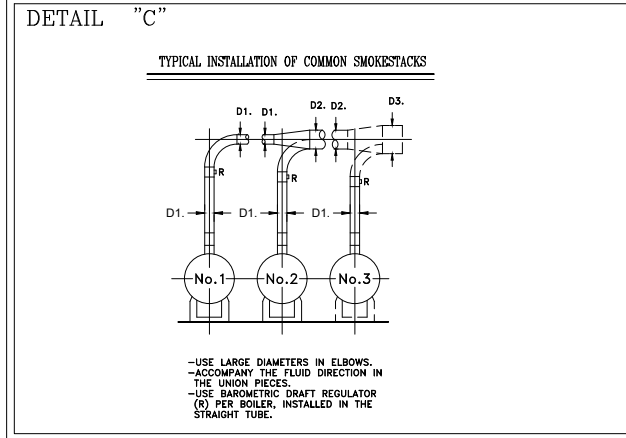
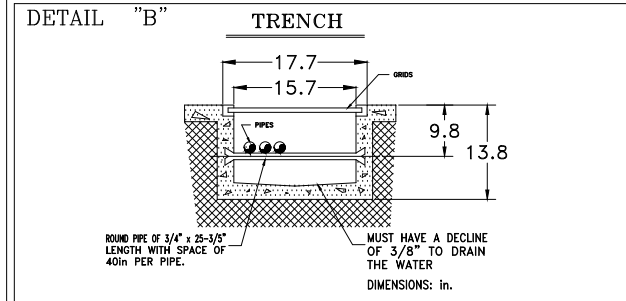
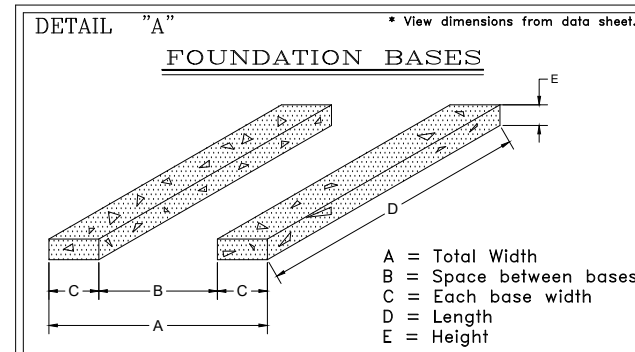

* Check dimensions with your representative

		TERMODINAMICA ENICA S.A. DE C.V. <small>Blvd. Dr. Jorge Jiménez Cantó S/N Plaza Antigua Edif. 3 Int. 316 Col. Hacienda de Valle Escondido Atzacán de Zaragoza, Estado de México C.P. 52937 Tel. 53-93-57-11 / 84-49</small>	
		Powermaster WB-A2-4P 80 HP	
DIMENSIONING:	in	PROJECT:	LAYOUT
PAGE:	3 / 3	FUEL:	HEAVY OIL, LIGHT OIL, GAS, DUAL
DRAWN BY:	ING. J. DOMINGUEZ	REVIEWED BY:	SALES DEPT.
		AUTHORIZED BY:	ING. J. NOTHOLT